

**PARTS LIST and INSTALLATION INSTRUCTIONS**

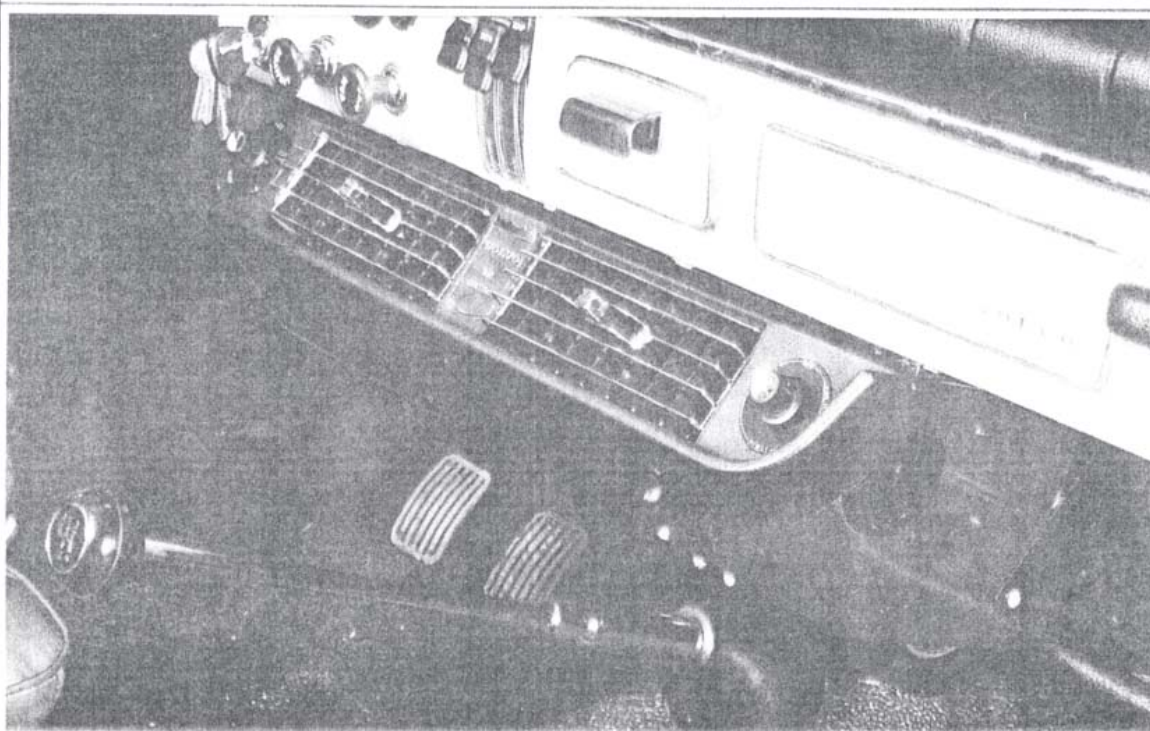

**VOLVO F-500 EVAPORATOR KIT**

**122S and P 1800 SERIES**

**91-09072**

**279910**

91-09073 Rev. B

## PARTS LIST

91-09072		VOLVO EVAPORATOR KIT		279910
122S and P1800 SERIES				5/3/68
Rev.	Qty.	Frigiking Pt. No.	Volvo Pt. No.	Description
	1	91-09072	279910	EVAPORATOR SECTION ASSEMBLY (F-500)
	1	63-00328	75421	RECEIVER-DRIER
	1	15-01014	75385	CLAMP, RECEIVER-DRIER
	2	91-09949	75423	HOSE, DRAIN, 3/8 ID x 15
	1	15-00149	75377	BRACE, BACK 12"
	1	83-00010		SEAL, PERMAGUM, 1/8 LB.
	1	91-13688		SACK ASSEMBLY, EVAPORATOR (Includes the Following:)
	2	54-00176		CLAMP, HOSE
	2	54-00207	75410	CLAMP, HOSE
	1	17-52002		SCREW, #8 x 1/2 PPH
	3	50-01550		SCREW, #10 x 5/8 SHWH
	1	17-09105		SCREW, MACH. 10-32 x 1 PPH
	1	91-10576		SCREW, MACH. 10-32 x 2 PPH
	2	50-03020		NUT, HEX 10-32 PLAIN
	2	16-90101		WASHER, FLAT, #10 USS
	2	50-04060		WASHER, SPRING LOCK #10
	1	16-90301		WASHER, FLAT, 7/16 SAE
	2	17-52005		SCREW, #8 x 3/8, PPH
	1	16-91301		NUT, HEX LOCK, 10-32
	1	03-00194		SPACER, 9/32 x 5/8 x 1"
	1	15-00154	75378	BRACE EVAP. CASE
	1	15-00155	75379	BRACE ASSY. PACKAGE TRAY

Check contents carefully. Report any shortages to Volvo.

91-09073 Rev. B

# GENERAL INSTRUCTIONS

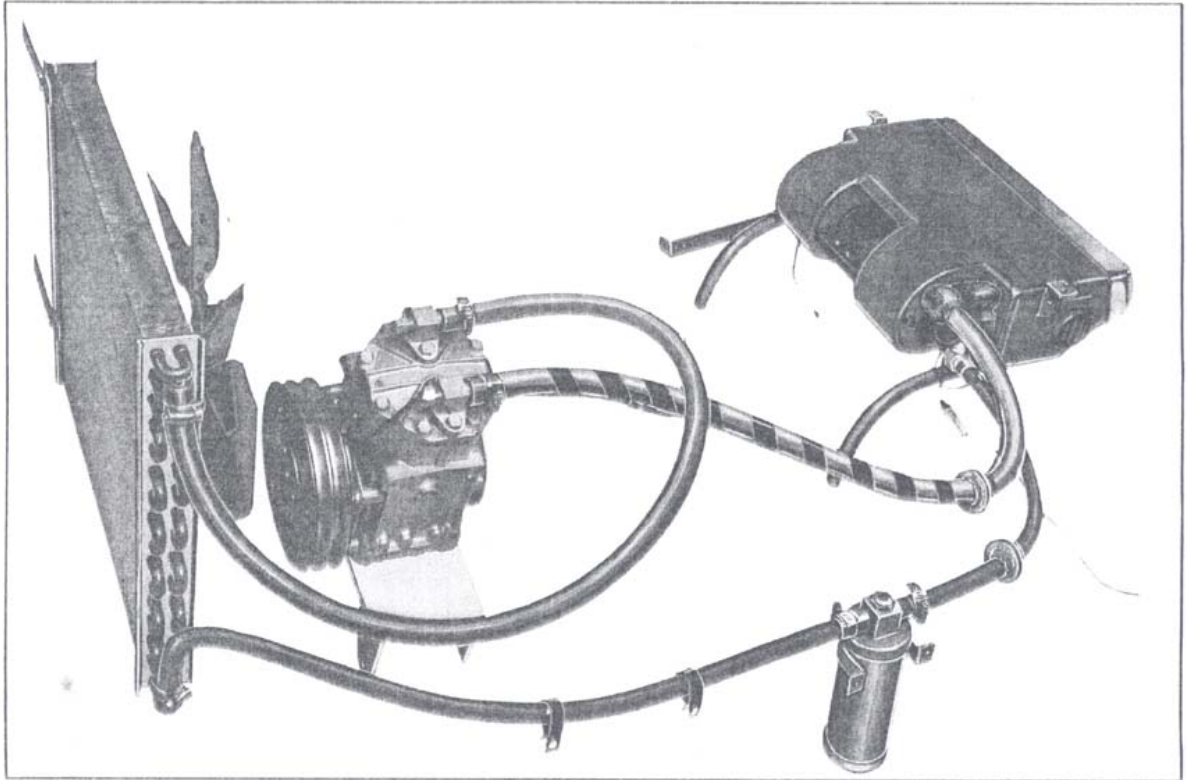

## A. PREPARATION

1. Check parts received against parts list for broken or missing parts
2. Disconnect battery as a safety precaution.
3. Drain and retain coolant from radiator.
4. Disconnect and cap transmission coolant lines from the radiator.
5. Remove engine fan and shroud.
6. Remove radiator for easier drive pulley and condenser installation.

## B. COMPRESSOR DRIVE PULLEY

1. On some vehicles you will be able to use a groove on the original drive pulley, others you will have to install either a replacement or an add-on compressor drive pulley.
2. Refer to the illustration supplied with the adapter kit for detailed instructions for installing the specific drive pulley. CAUTION: When installing a drive pulley be certain the seating surfaces are clean and that all the bolts are tightened evenly.
3. Check for pulley wobble.

## C. INSTALLING THE COMPRESSOR AND CLUTCH

1. It is usually convenient to attach the clutch to the compressor before the compressor is installed on the mount. (Follow the instructions and use hardware supplied with the clutch.)

2. The clutch wire will be attached to the thermostat wire routed along the 5/8" suction hose.
3. Place compressor mount in its approximate mounting position. If at this time it becomes apparent that the compressor mounting bolts will be inaccessible when the compressor mount is attached to engine, it will be necessary to install the compressor first, then attach the compressor mount assembly to the engine. If the compressor mounting bolts will be readily accessible, secure the compressor mount to the engine, then install the compressor to the compressor mount.

## D. INSTALL THE COMPRESSOR MOUNT ASSEMBLY

1. With the mount held in its mounting position, determine the mount attaching points and engine bolts to be removed.
2. Follow the instructions contained in the adapter kit to determine the proper length and size of bolts and spacers to be used when installing the compressor mount.
3. Tighten all bolts evenly to prevent warpage of the mount.  
**NOTE:** On aluminum block engines, use an "anti-seize" compound on all bolts.
4. Install the idler eccentric/s and idler pulley/s. The pulley alignment is very important. To check alignment use a metal straight edge against the front surface of the clutch and drive pulley. You can correct the idler pulley alignment by adding or subtracting the spacers and/or spacing washers between the eccentric and the idler pulley.



## E. INSTALL THE CONDENSER

1. When the condenser is installed there should be one half inch to one inch clearance between the condenser and radiator fins.
  2. Place the condenser in front of the radiator with the refrigerant fittings on the same side of the radiator as the compressor. The 1/2" fitting must be on top and the 3/8" fitting on the bottom.
  3. With the condenser in mounting position determine the location and position of the condenser brackets to be used. The condenser may be secured in position by:
    - (a) attaching the condenser flange directly to the radiator cowl.
    - (b) attaching the condenser brackets (supplied with the condenser) to the condenser flange then to the radiator cowl.
    - (c) using special condenser mounting brackets (supplied with the adapter kit, if required.)
- NOTE: It may be necessary to modify or trim some parts of the vehicle to obtain clearance for the condenser.
4. Secure the refrigerant hoses to the condenser.
  5. Secure the condenser in position.
  6. Reinstall the radiator in its original position.

## F. INSTALL THE FAN

NOTE: A heavy duty fan will improve the efficiency of the cooling system in any vehicle; therefore, we recommend their use for maximum unit performance. It will be important to use a heavy duty fan when the vehicle is driven in parts of the country that have sustained temperatures above 90°F or when driven in heavy stop and go traffic.

Be certain the fan clears the clutch, drive pulley, and radiator.

## G. INSTALL THE DRIVE BELT

1. Install the compressor drive belt around the pulleys and adjust belt tension by rotating the idler eccentric. If a belt tension gauge is used, belt should be tensioned to 90-100 lbs. and used belts 65-75 lbs. If a belt tension gauge is not used, an adjusted belt will depress 5/8" per foot of belt span. CAUTION: Do not over-tighten belt.
2. The belt should be checked for tension after a few hours of operation usually one week is sufficient.

## H. POSITIONING THE STANDARD UNDER-DASH EVAPORATOR CASE ASSEMBLY

(for custom evaporator kits, follow the instructions supplied with the custom evaporator)

1. Hold the evaporator case in mounting position parallel to the underside of the dash, keeping the unit as close to the exact center as possible. Insure sufficient clearance for accelerator pedal, glove box, and any other accessories. Mark hole locations for mounting brackets and condensate drain hoses (these brackets are a universal type angle bracket and may be adjusted to meet any mounting situation.)
2. After marking hole locations for refrigerant hoses, mounting brackets, and drain hoses, remove evaporator case from vehicle.

3. Remove and relocate switches or other obstructions attached to underside of center section of dash.

## I. LOCATE HOLES FOR CONDENSATE DRAIN HOSES

1. Locate holes for condensate hoses in floorboard behind the evaporator case assembly location. Check hole locations to be sure hoses will not be obstructed on underside of floorboard when installed.
2. On cars with carpeted flooring instead of a rubber mat, cut carpet with a knife, using an "x" pattern. Lift carpet insulation at cut to provide clearance for hole saw so that carpeting and insulation will not snag and unravel on the hole saw.

## J. INSTALL REFRIGERANT HOSES

### PRECAUTIONS:

- (1) Use refrigerant oil on all hose fittings and connections.
- (2) Caps and plugs should not be removed until refrigerant hoses are ready to be connected.
- (3) Avoid sharp bends when installing hose and do not clamp hoses too close to the compressor. Route hoses so that they do not touch hot or moving parts of the engine.
- (4) Where hoses pass thru the firewall and radiator cowl, install grommets to prevent cutting hoses on sharp metal edges.

1. These steps must be followed to install a hose on a push-on fitting.
  - a. Cut the hose with a knife and clean any fragments out of hose. Do not use a hack saw.
  - b. Oil the inside of the hose and outside of fitting.
  - c. Clamp must be positioned so that tab is over end of hose and flush with end. This must be done in order that the clamp be properly positioned on the hose and over the barbed section of the fitting.
  - d. Push hose on fitting with rotating motion until the fitting is completely inserted in the hose.
  - e. Tighten clamp.
2. Slide necessary grommets and hose clamps on before installing hose.
3. Cut 1/2" refrigerant hose to length and install on compressor discharge valve.
4. Insert 5/8" refrigerant hose thru hole cut in firewall and connect 5/8" hose to the evaporator. Cut hose to length and install on the suction port of the compressor.
5. Insert 3/8" hose thru hole cut in firewall and connect the hose fitting to the evaporator expansion valve.

NOTE: This hose must be routed by the receiver-drier and with enough length to cut the hose and connect it to the receiver-drier fittings.

6. After the hoses are connected to the evaporator wrap the metal portion of the suction hose and the exposed portion of the expansion valve diaphragm on the evaporator. This will prevent these lines from forming condensate which might drip on the floor of the vehicle.
7. Locate suitable location for receiver-drier on fender-well of vehicle and secure. Receiver-drier should be as close to upright as possible.  
IMPORTANT: Inlet of receiver-drier faces condenser and outlet faces evaporator, do not reverse the receiver-drier.
8. Cut 3/8" refrigerant hose at location of receiver-drier. Install hoses to receiver-drier.
9. Seal gaps where hose passes thru firewall with Permagum sealant supplied in kit.
10. Install hose clamps as necessary to secure hoses in position. Secure all hoses with clamps.

#### K. INSTALLING ELECTRICAL WIRING

1. Connect short 14 ga. wire extending from evaporator case to the accessory terminal on ignition switch or the fuse panel if provision has been made for an air conditioner.
2. Route the long 16 ga. wire from the evaporator case along 5/8" refrigerant hose thru the firewall and connect it to the wire from the electric clutch.  
NOTE: Tape wire to suction hose to prevent contact with moving or hot parts of the vehicle.
3. Connect car battery.

#### L. INSTALL EVAPORATOR CASE ASSEMBLY

Install evaporator drain hoses. Using screws, mount evaporator case assembly to dash, extending condensate drain hoses thru holes in floorboard. If hoses do not extend thru floorboard, water draining from the evaporator pan will damage carpet.

#### M. CHECKING AND EVACUATING THE SYSTEM

1. Checking: Add refrigerant to the system until a pressure of 40 P.S.I. is reached on low side gauge. Check for leaks and repair as necessary.
2. Evacuating:
  - (a) The compressor suction and discharge ports are identified at the ports. With both gauge manifold valves closed, connect manifold hoses to respective compressor service ports. CAUTION: Schrader valve charging hose or adapters must be used or the system cannot be evacuated.
  - (b) Attach manifold gauge charging hose (center hose) to vacuum pump and start pump. Open both manifold valves slowly to prevent discharge of oil from compressor and evacuate system for 30 minutes. A reading of 28" of vacuum at sea level pressure should be obtained on the low side gauge. If this reading is not obtained within this period, make sure all connections are tight.
  - (c) Close both charging manifold gauges for 5 minutes. Check low side reading before closing. If reading shows a rise in pressure after closing gauges, check for leaks.
  - (d) Repair leaks as necessary.
  - (e) Reconnect the vacuum pump and proceed with evacuation of the system for at least 30 more minutes.

#### N. PRELIMINARY CHARGING INSTRUCTIONS

1. Close manifold gauges and disconnect the charging hose from the vacuum pump. Install manifold gauge set.
2. Attach manifold charging line (center line) to charging valve on refrigerant can or drum. Be sure can or drum is right side up for refrigerant.
3. Open refrigerant can or drum charging valve slightly to allow refrigerant to flow into charging line.
4. Partially open charging line fitting at manifold gauges to purge air from line. Purging is very important because air and moisture in the line will cause problems in the system. As soon as line is purged, close fitting.
5. Open refrigerant can or drum charging valve all the way and open manifold gauge to suction side valve. The first pound of refrigerant will be pulled into the system if a good vacuum has been held.

#### O. FULL CHARGE INSTRUCTIONS

1. Start the car engine, set on fast idle, and on hot days place a large fan in front of the radiator, blowing on condenser coil and radiator.
2. Connect the second can of refrigerant to charging hose and continue to charge the system. Check the sight glass and when all the bubbles and foam disappear from the sight glass the unit is fully charged.  
WARNING: Do not exceed a charge of 2 1/4-2 1/2 lbs.
3. Close the low side manifold gauge valve. At a temperature of 80° the low side gauge should read 20-40 P.S.I. and the high side gauge should read 180-200 P.S.I. (higher on warmer days and lower on cooler days).
4. Close refrigerant can or drum charging valve all the way and disconnect charging line from refrigerant can or drum. CAUTION: Be certain that charging line is pointed downward and away from face and other parts of the body as well as from car paint.
5. Disconnect manifold lines from compressor and replace compressor valve port caps.

#### P. CHECK OUT AFTER CHARGING

1. Allow engine to run at fast idle.
2. Test unit for leaks.
3. Check fan speed control switch for proper operation.
4. Check Thermostat to be sure unit cycles on and off. This should be done with doors and windows closed. With car interior cool, the compressor clutch should be made to disengage and engage by moving the thermostat lever or knob.
5. Road test the car. Be sure and check for engine over-heating and noises which may be caused by the installation.
6. Recheck the belt tension. (Refer to Step G-1, Installing drive belt)
7. After repairing any discrepancies found during checking and road testing the vehicle is ready for delivery to customer.



## INSTALLATION INSTRUCTIONS

91-09072

### 1. Cut Holes in Firewall for Refrigerant Hose Passage:

#### P-1800 Only (See Detail A):

- On the engine compartment firewall between the heater/ventilation motor housing and the clutch/brake pivot housing, measure from top edge of firewall bend, down 2-1/2". Measure over from brake/clutch housing 1-1/2" and at this point, punch a guide hole.
- Measure from top edge of firewall bend, down 5". Measure over from brake/clutch pivot housing a 1-1/2" and at this point, punch the second guide hole.

#### 122-S Only (See Detail B):

- On the engine compartment firewall between the heater/ventilation motor housing and the clutch/brake pivot housing, measure from top edge of firewall bend, down 5". Measure over from brake/clutch housing 1-1/2" and at this point punch a guide hole.
- Measure from top edge of firewall bend down 7-1/4". Measure over from brake/clutch pivot housing 1-1/2" and at this point punch the second guide hole.

#### All Models:

- At locations marked, cut two 1-1/2" holes. Thread the 3/8" refrigerant hose thru the lower hole, and onto floor under the dash.
  - Insert one of the rubber grommets into the hole and around hose to protect against cutting the hose.
2. P-1800 Only: Remove the heater and ventilator control unit for relocation:
- Remove heater and ventilator control unit from under the dash by cutting original mounting bracket flush with the underside of dash. File down any sharp edges that may remain at bracket stub.
  - Remove the two original screws from bottom of cut bracket and discard bracket. Use the original screws to attach the control unit to the new Heater-Control bracket furnished.
  - Mark and drill a 1/8" hole in the center of the lip at the top of the control unit. (See Detail C) Attach the Control Bracket Clip at this point using one #8 x 1/2" Sheet Metal Screw.
  - Thread the control unit and its cables over the heater ducts and underside wirings, then temporarily tape it out of the way on the right side of the dash.
3. 122-S Only: Remove the lower dash-pad from bottom flange of the dash, if so equipped.
- Remove the eight sheet metal screws and washers holding the dash-pad, being sure to retain the pad and six of the screws with washers.

(Text Continued on Page 6)

**DETAIL A**  
FIREWALL HOLES FOR P-1800

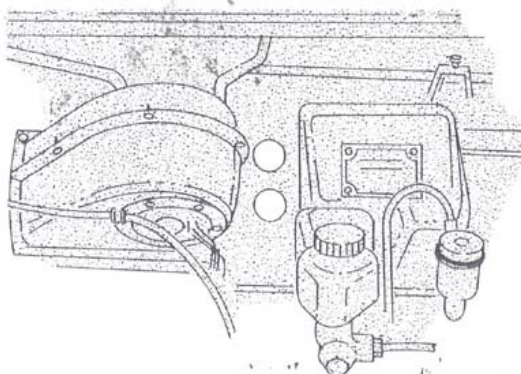

**DETAIL B**  
FIREWALL HOLES FOR 122-S

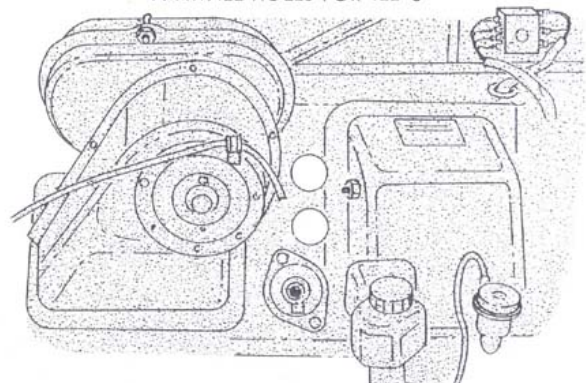

**DETAIL C** EVAPORATOR ASSEMBLY INSTALLATION FOR P-1800

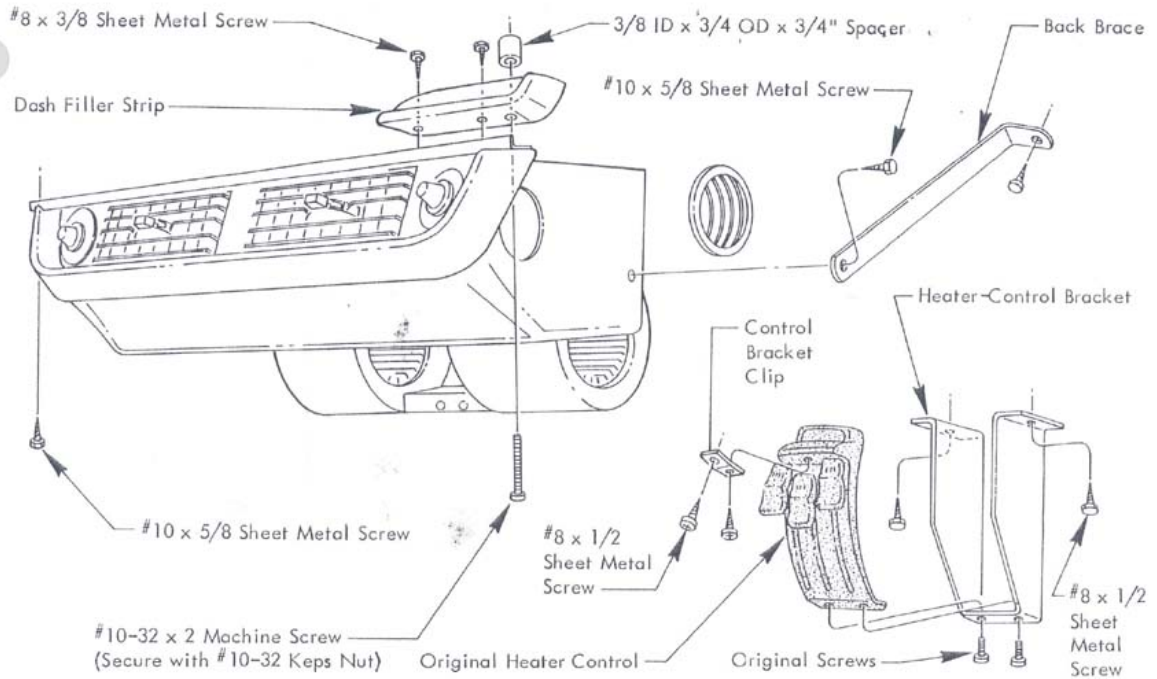

**DETAIL D** EVAPORATOR ASSEMBLY INSTALLATION FOR 122-5

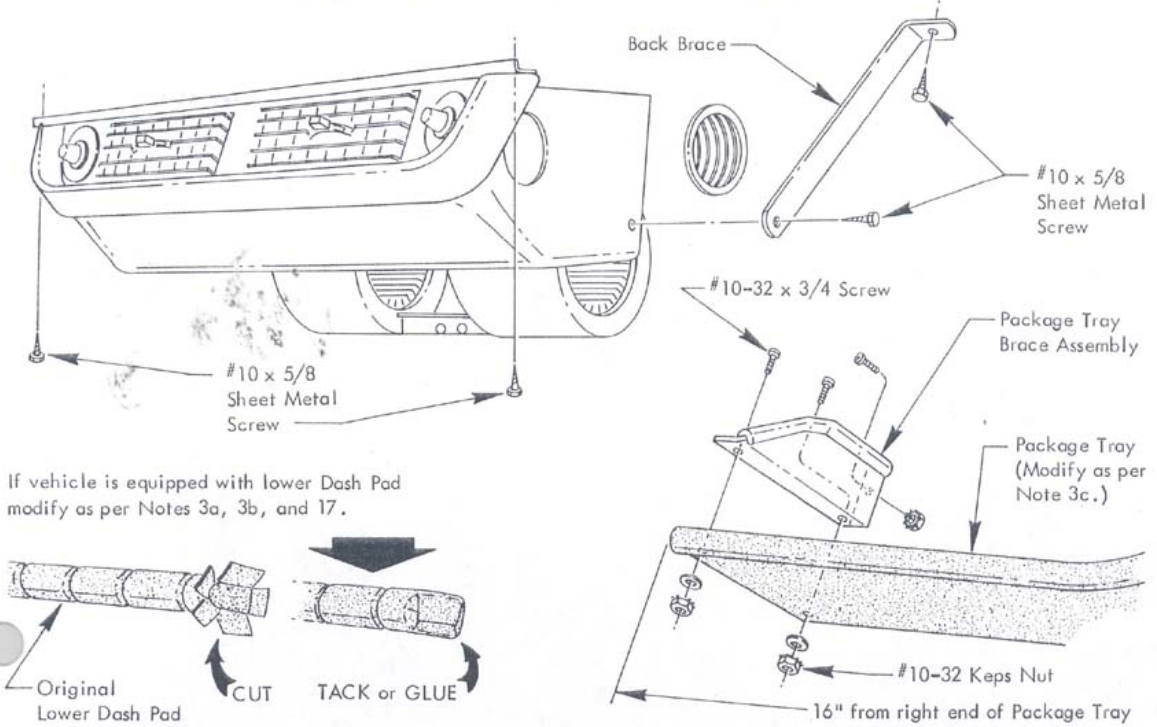



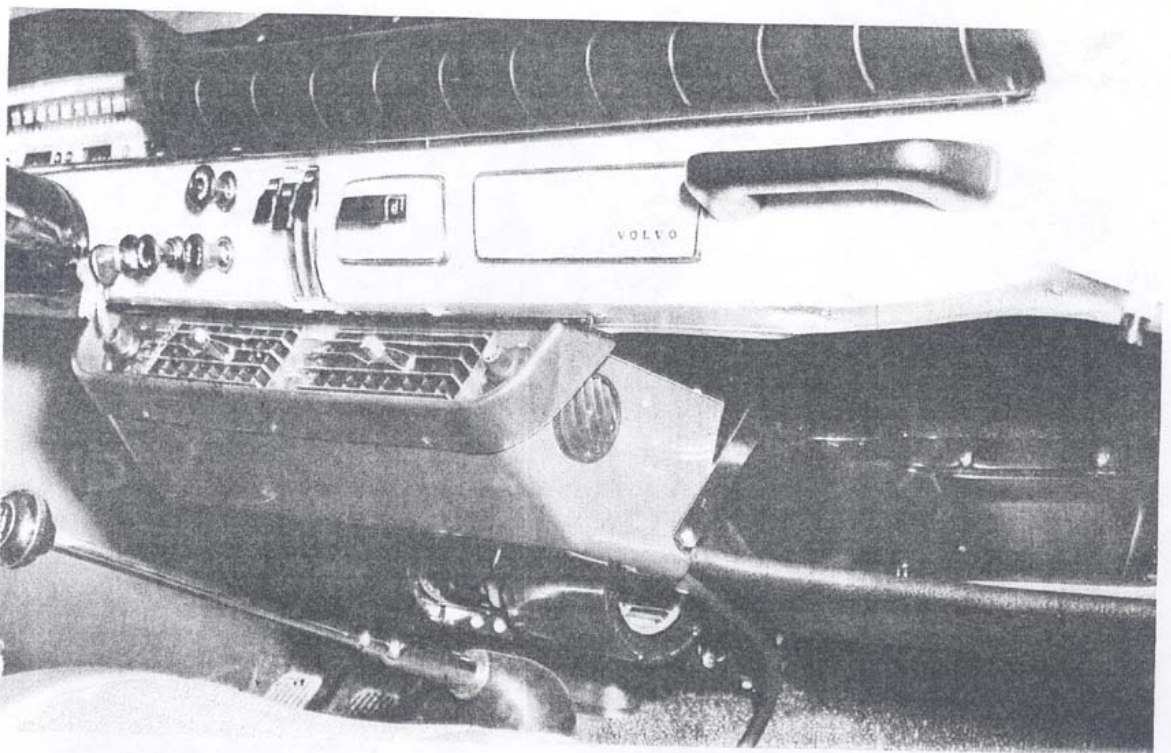
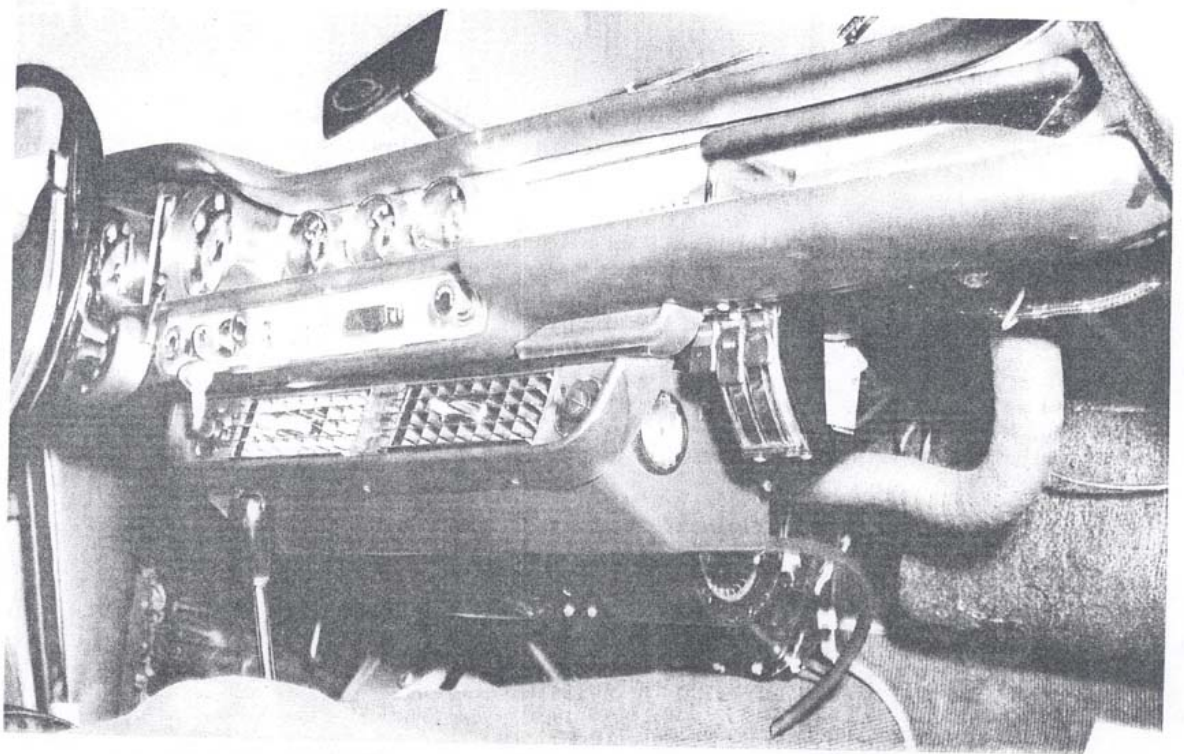



91-09072

- b. File clean any protruding metal from the two holes on each side of the center section.
- c. Remove the underdash package tray and measure 16" from the "passengers" end of the package tray. At this point, cut the package tray (See Detail D) and install the Package Tray Brace Assembly using three #10-32 x 3/4 Machine Screws with Flatwashers and #10-32 Keps Nuts.

**NOTE:** All Models: Before beginning the installation of the evaporator case, remove the black plastic air louvers in each end of the evaporator case in order to give working clearance and to prevent possible damage to them.

4. P-1800 Only: Attach the dash filler strip to the evaporator case:

- a. Place the plastic filler strip on the right end of the evaporator case mounting bracket (See Detail C) and temporarily hold the evaporator case in mounting position under the dash (the nameplate on the evaporator case should align with the center of the transmission hump and center of the dash.)
- b. When proper alignment of filler strip is determined, mark its location and drill two 1/8" holes in the evaporator case bracket using the filler strip as a template. Attach the filler strip to the bracket with two #8 x 3/8" Sheet Metal Screws.
- c. The evaporator case mounting bracket has two pre-drilled holes. To be sure alignment is good between case and the bracket, run a 1/8" drill thru the left side hole and a 7/32" drill thru the right side hole.  
**NOTE:** When drill checking the right side hole, drill thru outer, upper edge of the plastic filler strip so that the attaching hardware will pick-up the filler strip.

5. Install the evaporator case to underside of vehicle dash:

- a. Temporarily hold the evaporator case in mounting position. Using the two pre-drilled holes in the evaporator case mounting bracket as a template, mark hole locations on the flange on the underside of the dash.
- b. P-1800 Only:  
Remove evaporator case and drill one 1/8" hole at the location marked on the left and a 7/32" hole at the location marked on the right. Use caution when drilling thru dash so as not to drill thru power cables or other underdash items.
- c. 122-S Only:  
Remove evaporator case and drill two 1/8" holes at the locations marked.
- d. With the evaporator case resting on the floor under the dash, remove the plastic protection caps from refrigerant connections and attach the refrigerant hoses to the evaporator. Wrap all exposed metal connections (with the exception of the expansion valve) with the permagum strip to prevent condensate from forming and dripping onto the floor of the vehicle.
- e. Thread the 5/8" hose thru the upper hole of the two 1-1/2" holes cut in firewall. From engine side, insert the rubber grommet into the hole and around the refrigerant hose.
- f. P-1800 Only:  
Attach the evaporator case to the dash using a #10 x 5/8" Sheet Metal Screw on the left end of the mounting bracket. On the right side, insert the 1" Spacer into the dash filler strip and use a #10-32 x 2 Machine Screw with Keps Nut.
- g. 122-S Only:  
Attach the evaporator case to the dash using two #10 x 5/8" Sheet Metal Screws.

6. Install the evaporator back-brace:

- a. Temporarily hold the back brace in mounting position at the right side of the evaporator case. Mark mounting hole location on the firewall.
- b. P-1800 Only:  
Locate the hole in the evaporator case 1/2" from back edge of case, and 2" up from the bottom of the case. With the brace at this location on the evaporator case, the other end of the brace will fit against the firewall, near the outer screw of the heater terminal. Mark mounting hole location on the firewall.
- c. 122-S Only:  
Locate the hole in the evaporator case 1/2" from back edge of case, and 1" up from bottom of case. With the brace at this location on the evaporator case, the other end of the brace will fit against the firewall, against the underside of the ridge where the firewall padding ends and just inside of the seam of the padding.

**DETAIL E** GEAR SHIFT MODIFICATION FOR 122 S

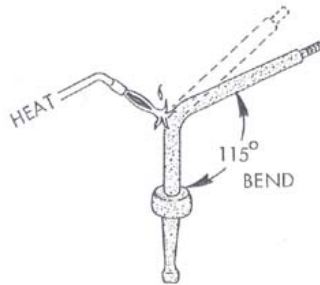

Clamp lower section in a vise.

Carefully read Note 8.



Temporarily remove boot, chrome section of gear-shift and rubber bushing.

- d. Drill 1/8" hole at the location marked, using caution not to drill thru the firewall into the battery or other vehicle components. Use two #10 x 5/8" Sheet Metal Screws to secure the brace to the firewall and the evaporator case.
7. Install the evaporator case drain hoses:
    - a. Push drain hoses onto the two outlet tubes at back of the evaporator and secure them with the clamps provided.
    - b. Mark drain hose locations on the rug covering the transmission housing. (See Photo, page 5)
    - c. For each location, use a sharp instrument and cut a small "x" in the carpet. (Lines of the cut should not exceed 3/4") Lift the four flaps formed by this cut and drill a 1/2" hole.  
CAUTION: Be careful not to drill into the transmission assembly below.
  8. 122-S Only: After the gear shift to clear the forward edge of the evaporator case:
    - a. With the gear shift lever in first gear, measure from edge of evaporator case to shift lever. This measurement must be increased until clearance is 2-1/2".  
NOTE: Do not attempt to alter gear shift position by using force to bend it down while in position. This will damage the gear mechanism. Also attempting to heat the elbow of gear shift and bending it in place (without removing it from the car) will result in heat damage to the rubber connector between the elbow and the shaft.
    - b. Take up floor mat (rug) from around gear shift. Lift the plastic heater air-duct that rides over transmission tunnel housing. This will free the rubber boot around the gear shift. Slide the boot up, remove the gearshift knob, and temporarily remove the boot.
    - c. With the rubber boot out of the way, remove the hex cap that holds the gear shift in place. Remove the gear shift lever from transmission by pulling upward.
    - d. With the gear shift lever out of the car, remove the ring clip and unscrew the lower (angled) portion of the shift lever. Do not damage the rubber connector.
    - e. Remove other components from the angled portion (elbow) and place elbow in a vise. Use a protractor and measure the degree of angle.
    - f. Heat the elbow with a torch and bend it down until the angle is 115°. This will give a clearance of 2-1/2" from edge of the evaporator case to gear shift lever when the lever is in first gear.
    - g. Replace components on the gear shift lever and reinstall. In replacing the rubber boot, work it beneath the plastic heater air-duct and then replace the floor mat.
  9. P-1800 Only: Reattach the heater and ventilation control unit to the dash:
    - a. Mount the control unit just to the right of the evaporator case. Hold the control unit in mounting position and mark the two mounting hole locations under the dash.
    - b. Also mark the mounting screw location for the control bracket clip on the lower flange of the dash.  
NOTE: In mounting this control, keep passenger safety in mind and slope control with bottom back under the dash (as originally mounted).
    - c. Remove unit and drill three 1/8" holes as marked. Mount control unit, using three #8 x 1/2" Sheet Metal Screws.  
CAUTION: Make sure the control cables are not kinked or misaligned.

(Text Continued on Page 11)



91-09072

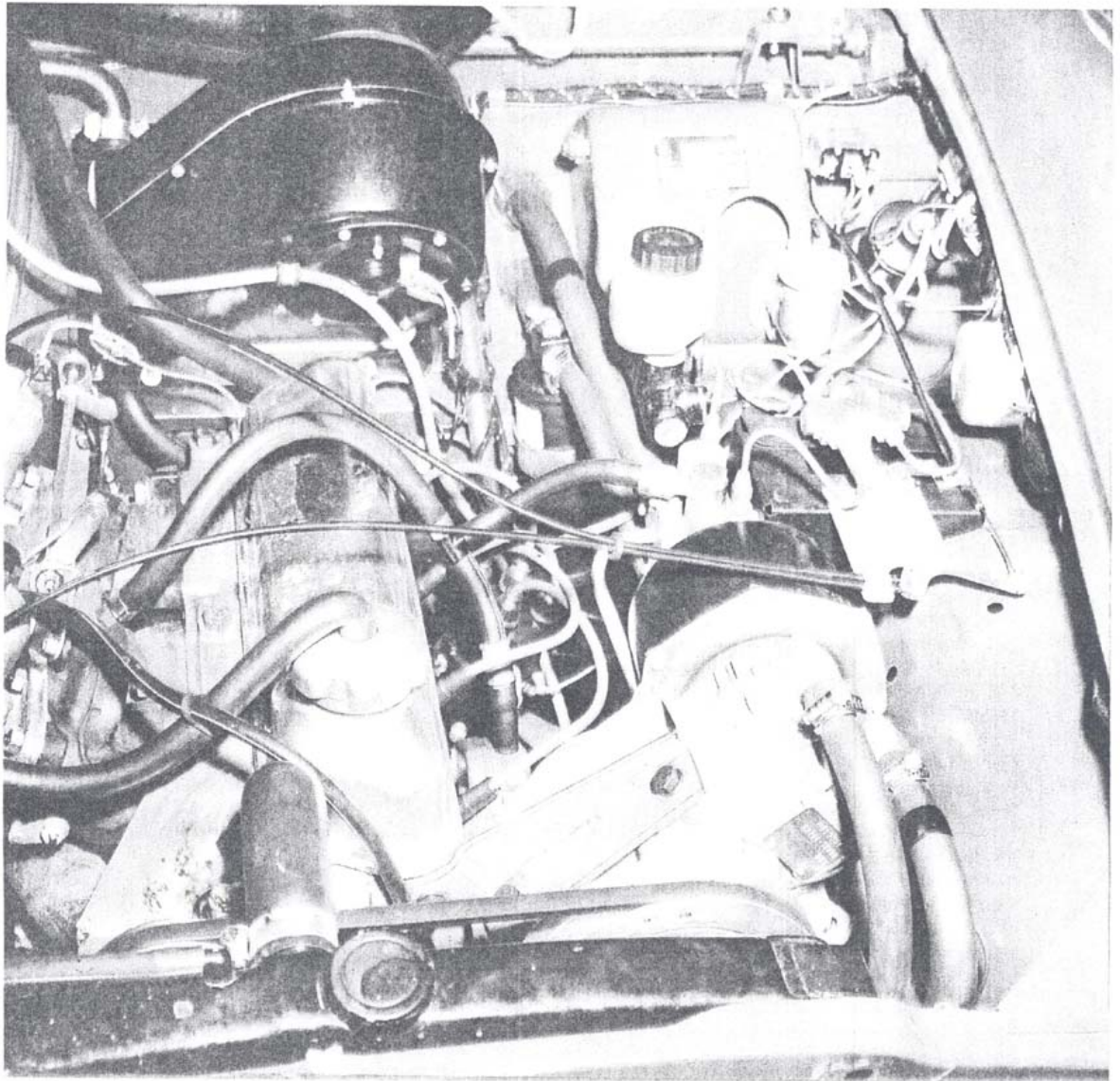



91-09072

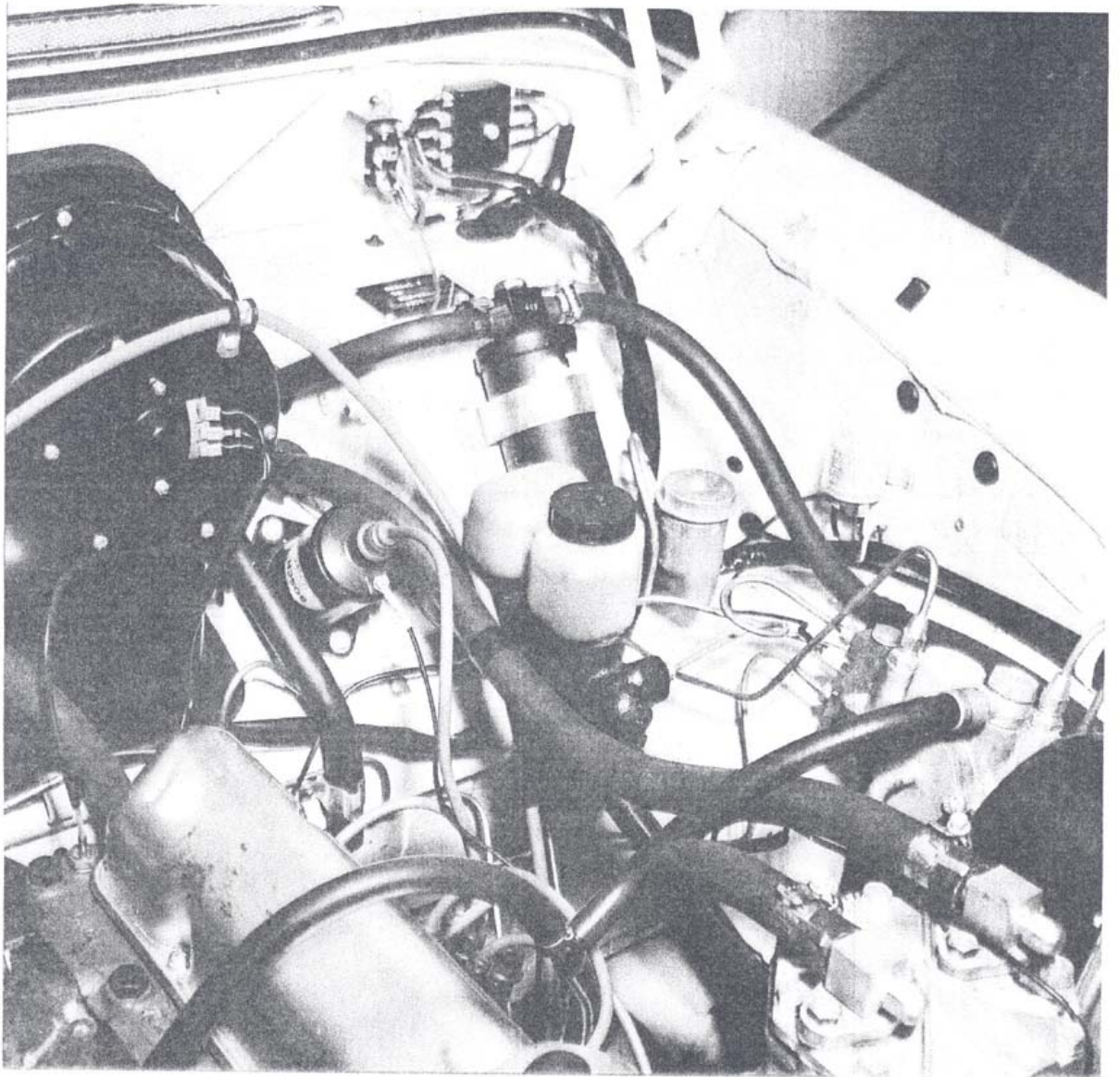

122 S ONLY

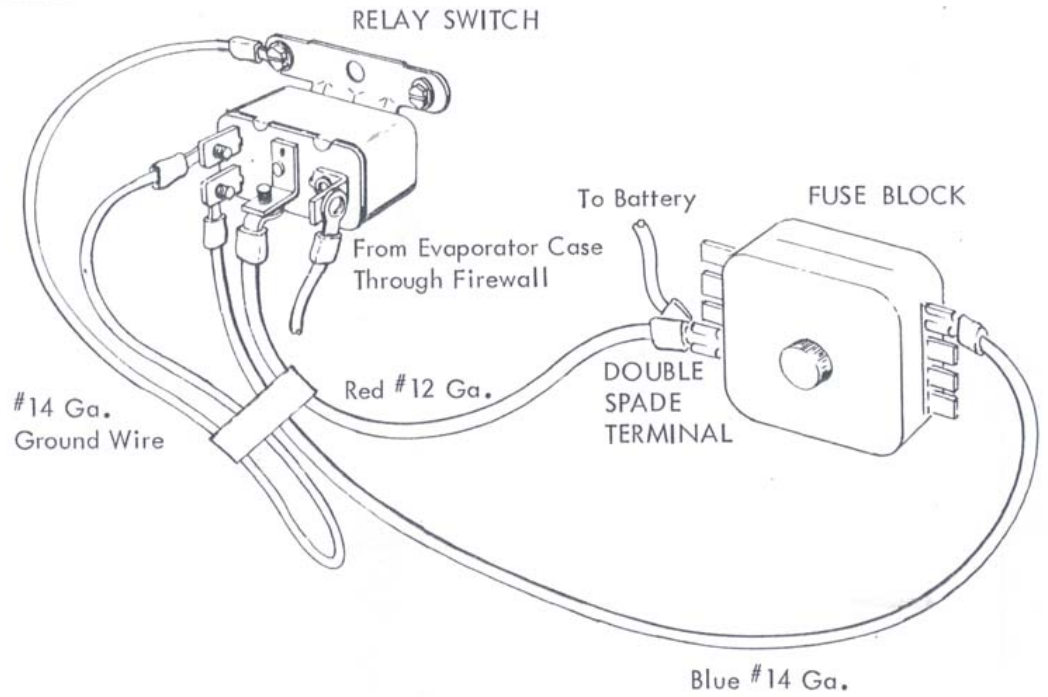

P 1800 ONLY

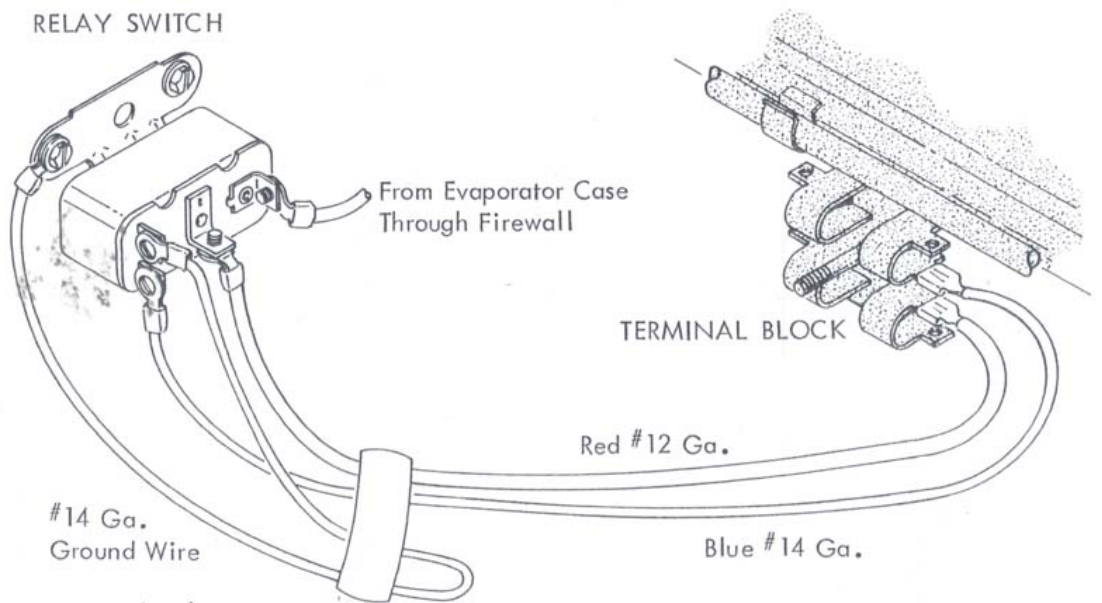

Install the 1/2" hose:

- a. If the 1/2" hose is not already connected to the condenser coil as outlined in the Adapter Kit Instructions, connect and route the 1/2" hose thru the lower hole of the two holes in the radiator cowlings.
- b. Route the 1/2" hose from the hole in the radiator cowlings to the compressor and connect it to the compressor discharge valve. Install the rubber grommet and secure the hose clamp.  
CAUTION: It is important that all hose routing avoids contact with hot engine surfaces; use the shortest route possible, avoid sharp bends and kinks.

11. Install the 5/8" hose (See Photo, page 8)

- a. Route the 5/8" hose from firewall under the brake booster unit. Run the hose along the fender seam and use the clamps provided to secure the hose to the fender. Where hose route joins the 3/8" hose routing, use the same clamps.
- b. Connect the 5/8" hose to the compressor suction valve.

12. Install the Receiver-Drier:

P-1800 Only:

- a. At a point just below the lower hole where the 3/8" hose (liquid line) comes thru the firewall into the engine compartment, there is a bend line. Mount the receiver-drier on the vertical surface of the firewall below this bend.
- b. Place the receiver-drier with its mounting clamp bracket in position and mark location where hose fittings of the receiver-drier will fit into the 3/8" hose. (See Photo, page 9) Also mark location for the mounting clamp attaching screws. Remove the assembly and drill two 1/8" holes.
- c. Cut the 3/8" hose with a sharp instrument and insert the fitting of the receiver-drier into the line, being sure it is installed with the refrigerant flow in the correct direction, as indicated on the receiver-drier. Clamp the hose to the fittings with the clamps provided. Place mounting clamp bracket around the receiver-drier and use two #10 x 5/8" Sheet Metal Screws to secure the assembly to the firewall.

122-S Only:

- a. At "drivers" side of the engine compartment firewall, between the heater/ventilation blower housing and the inner fender is the clutch/brake pivot housing. (See Photo, page 9) Temporarily hold the receiver-drier and mounting bracket on the surface of this pivot housing and using the mounting bracket as a template, mark locations for the two mounting holes. Remove the receiver-drier and drill two 1/8" mounting holes.
- b. Cut the 3/8" hose with a sharp instrument and insert the fittings of the receiver drier into the line being sure it is installed with the refrigerant flow in the correct direction, as indicated on the receiver-drier. Clamp the hose to the fittings with the two clamps provided.
- c. Place the mounting clamp bracket around the receiver-drier and use two #10 x 5/8" Sheet Metal Screws to secure assembly to the clutch/brake pivot housing.

13. Install the relay switch:

a. P-1800 Only:

On the "drivers" side of vehicle between inside of fender and the brake/clutch pivot housing, there is a ridge on the angle of the firewall. Temporarily place the relay switch in a centered position on this ridge and mark mounting holes for the two attaching screws. Remove the relay and drill two 1/8" holes. Mount the relay using two #10 x 5/8" Sheet Metal Screws. The relay should be mounted in a horizontal position that is not subject to moisture penetration.

b. 122-S Only:

Locate the fuse terminal on the "drivers" side of the engine compartment. There is sufficient room on the "passengers" side of the fuse terminal to mount the relay switch. Temporarily place the relay switch in this area and mark mounting holes for the two screws. Remove the relay and drill two 1/8" holes at the locations marked. Attach the relay using two #10 x 5/8" Sheet Metal Screws.



91-09072

14. Wire the relay switch into the vehicle electrical system:
  - a. P-1800 Only: Refer to Wiring Diagram (Page 10).
  - b. 122-S Only: Refer to Wiring Diagram (Page 10).
15. Route the compressor clutch wire:

Thread the "blue" wire from the evaporator assembly thru the firewall (with the 3/8" refrigerant hose). Bring it on up to a position beneath the 5/8" hose and route the wire along the 5/8" hose until it reaches the compressor. Connect the compressor clutch lead wire and the "blue" wire. Tape this wire at intervals along its route under the 5/8" hose.
16. Place permagum sealant around the holes in the firewall:

Where refrigerant hoses pass thru the firewall, use the permagum furnished to seal holes completely against engine noise and climatic conditions.
17. 122-S Only: Re-Install the lower dash-pad (See Detail D):
  - a. Hold the pad against the evaporator case face and mark the portion of the center section of pad that must be cut out.
  - b. Cut the marked amount from the pad. When cutting, leave sufficient fabric to fold over neatly. Glue or staple these flaps to the cut ends so as to form a neat appearance.
  - c. Attach these two altered portions of dash-pad to the right and left flanges of the lower dash with original attaching hardware.
18. Insert the side louvers into the evaporator case:

Press louvers into the holes at each end of the evaporator case, being sure that the wire keepers are fully in place.
19. Charge the system and check for leaks.